

D1

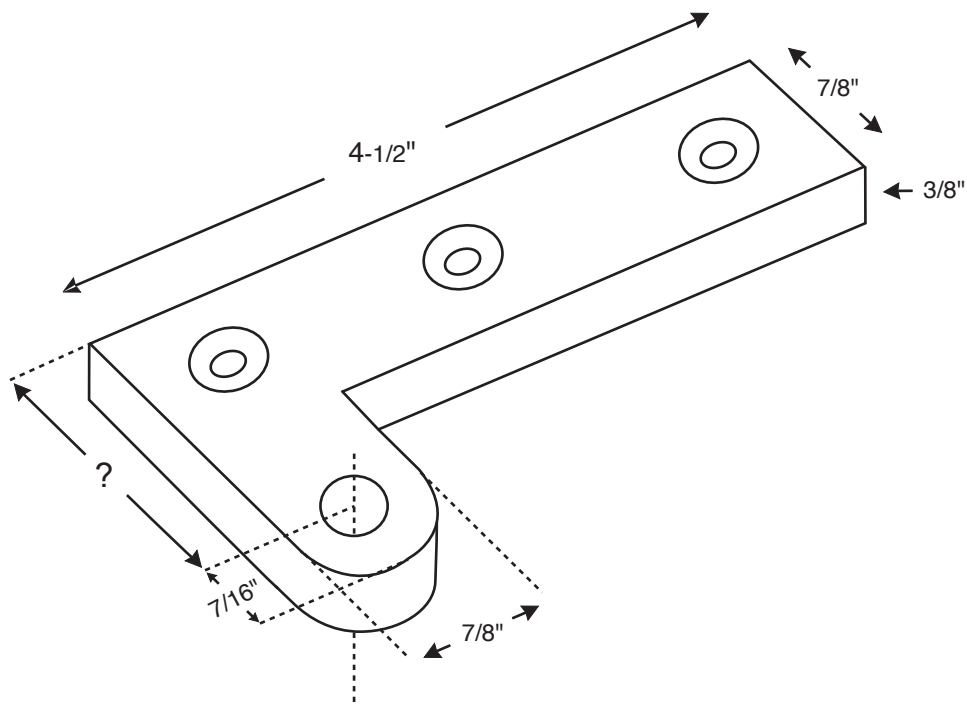

RIGHT HAND STANDARD DUTY SHOWN
Screw: 1 1/4 X #12

THRUST BEARINGS AND/OR
NEEDLE BEARINGS ADDED FOR
EXCESSIVE WEIGHT AND HEIGHT

(?) Projection Determined by Job Condition

USE H.D. 1/2" X 1" STOCK FOR DOORS
OVER 175 lbs. - 1-1/2" X #14 SCREWS

ALL PIVOTS ARE CUSTOM MADE
TO SUIT JOB CONDITION

D1 - Door Portion Offset Pivot Hinge

D2

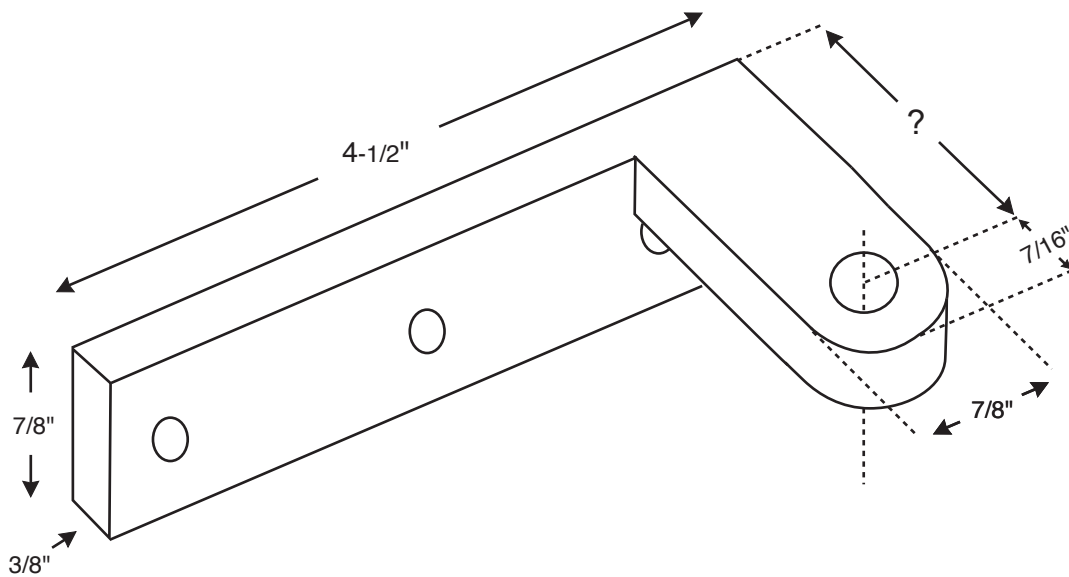

LEFT HAND STANDARD DUTY SHOWN
Screw: 1 1/4 X #12

THRUST BEARINGS AND/OR
NEEDLE BEARINGS ADDED FOR
EXCESSIVE WEIGHT AND HEIGHT

(?) Projection Determined by Job Condition

USE H.D. 1/2" X 1" STOCK FOR DOORS
OVER 175 lbs. - 1-1/2" X #14 SCREWS

ALL PIVOTS ARE CUSTOM MADE
TO SUIT JOB CONDITION

D3 / D3i

D3i is used with T4i
as an intermediate
back jamb pivot
set as: T4i x D3i

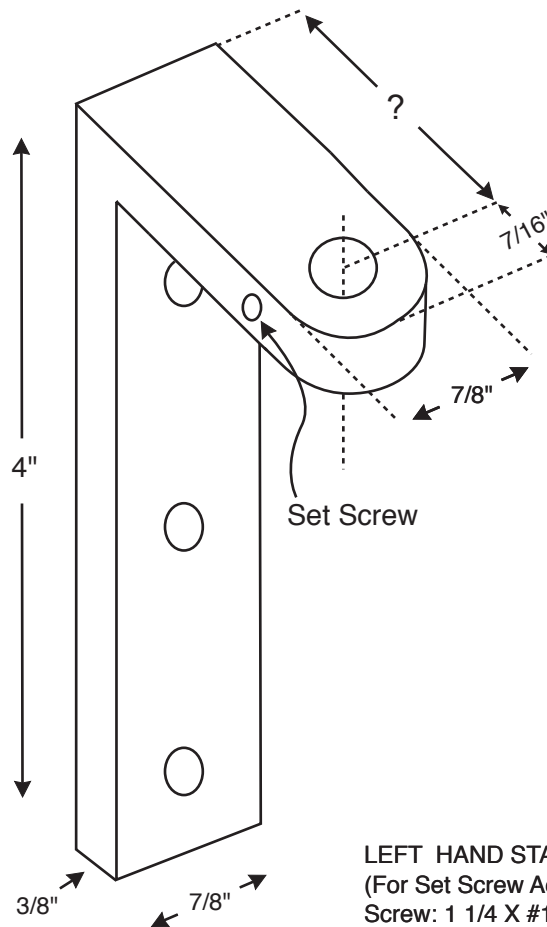

LEFT HAND STANDARD DUTY SHOWN
(For Set Screw Access)
Screw: 1 1/4 X #12

THRUST BEARINGS AND/OR
NEEDLE BEARINGS ADDED FOR
EXCESSIVE WEIGHT AND HEIGHT

(?) Projection Determined by Job Condition

USE H.D. 1/2" X 1" STOCK FOR DOORS
OVER 175 lbs. - 1-1/2" X #14 SCREWS

ALL PIVOTS ARE CUSTOM MADE
TO SUIT JOB CONDITION

D4 / D4i

D4i Is Used With
T5i or B3i As
An Intermediate
Side Jamb Pivot
Set As: T5i x D4i

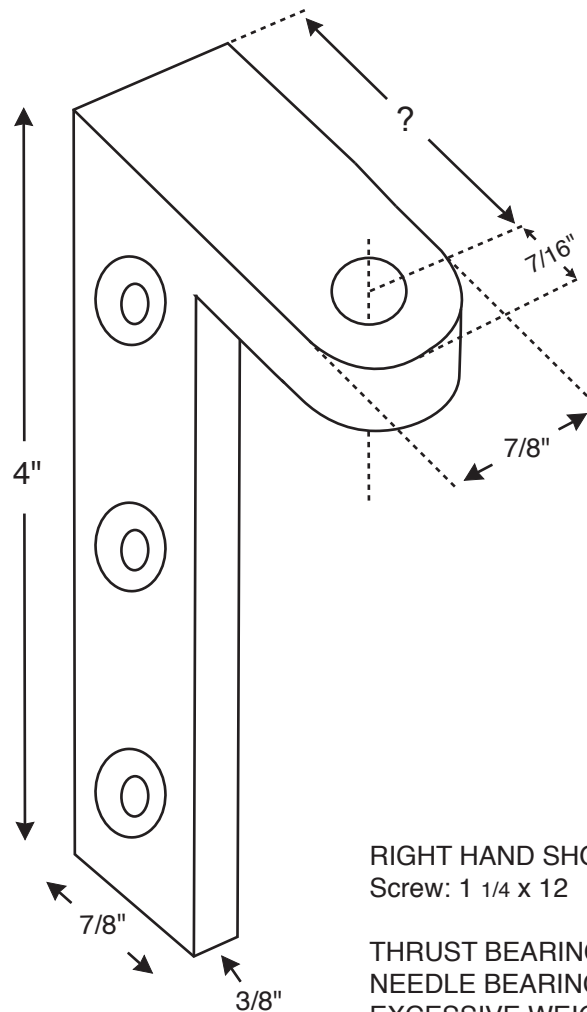

RIGHT HAND SHOWN
Screw: 1 1/4 x 12

THRUST BEARINGS AND/OR
NEEDLE BEARINGS ADDED FOR
EXCESSIVE WEIGHT AND HEIGHT

(?) Projection Determined by Job Condition

ALTERNATE FOR DOORS OVER 200 lbs.
IS 1/2" X 1" STOCK - 1 1/2" X 14 SCREWS

ALL PIVOTS ARE MADE TO ORDER
AND TO SUIT JOB CONDITION